



J-DRain 400 Series

3904 Virginia Ave • Cincinnati, Ohio 45227 • Phone (513) 271-6000 • Fax (513) 271-4420

Prefabricated Drainage Composite

J-DRain 400 Series performs a multi-faceted role by providing protection for waterproofing systems and managing sub-surface water around building foundations. A filter fabric retains the soil backfill and provides hydrostatic relief by allowing water to pass into the drainage core. The collected water is then conveyed to the **J-DRain SWD-6** or **SWD-12** collection systems.



J-DRain 400 / 420 maintains a very high flow rate while providing a higher compressive strength for greater depths and is a very popular choice for vertical and horizontal single-sided drainage applications. This product is for moderate duty. **J-DRain 400 XL / 420 XL*** is designed for extra heavy-duty vertical and horizontal applications that demand greater compressive strength and improved filtration for challenging soil conditions. It contains a heavier duty drain core & fabric.

* 420 & 420 XL are identical to 400 & 400 XL with the addition of a membrane protective film on the back side.

CORE	TEST METHOD	400 / 420	400XL / 420XL
Compressive Strength	ASTM D-1621	15,000 psf 719 kNm ²	16,500 psf 790 kNm ²
Thickness	ASTM D-1777	.40 in 10.16 mm	.40 in 10.16 mm
Flow Hydraulic Gradient = 1	ASTM D-4716	21 g/m/ft 260 l/min/m	21 g/m/ft 260 l/min/m
FABRIC	TEST METHOD	400 / 420	400XL / 420XL
Flow	ASTM D-4491	140 gpm/ft ² 5704 lpm/m ²	110 gpm/ft ² 4482 lpm/m ²
Puncture	ASTM D-4833	65 lbs .30 kN	95 lbs .42 kN
Apparent Opening Size	ASTM D-4751	70 US Sieve .212 mm	70 US Sieve .212 mm
Grab Tensile	ASTM D-4632	100 lbs .45 kN	160 lbs .71 kN

Roll Dimensions: 4' x 50', 6.5' x 50', 8.5' x 50'

The above information is to the best of our knowledge accurate, but is not intended to be considered as a guarantee. Any implied warranty for a particular use or purpose is excluded. If the Product does not meet the above properties, and notice is given to US Fabrics, Inc., the product will be replaced or refunded. (1/2009).

J-DRain 400 Series Applications

Foundation Walls
Retaining Walls
Planters & Roof Gardens
Bridge Abutments
Under Slabs

FOUNDATION WALL / RETAINING WALL

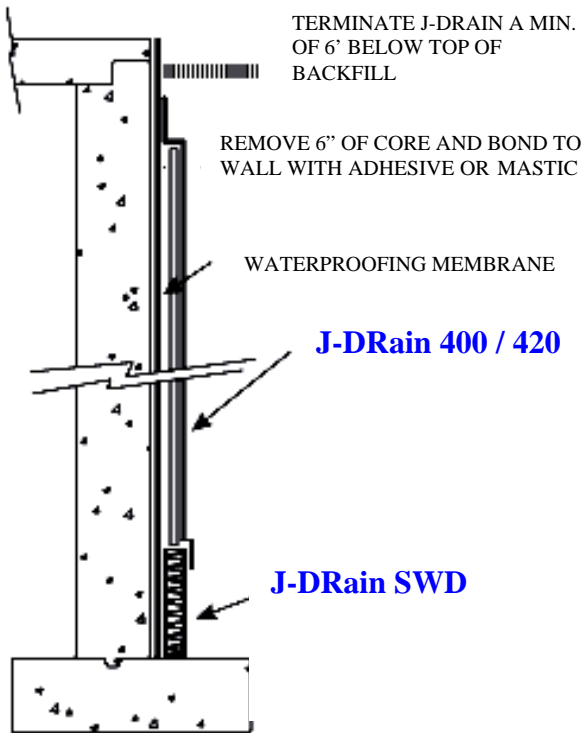

PLANTERS & ROOF GARDENS

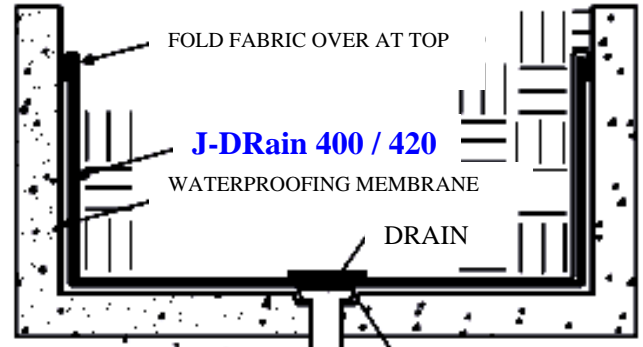

NOTE: When using J-DRain 400 / 420 cut and remove drainage core and cover with an aluminum plate as shown.

PLAZA DECKS

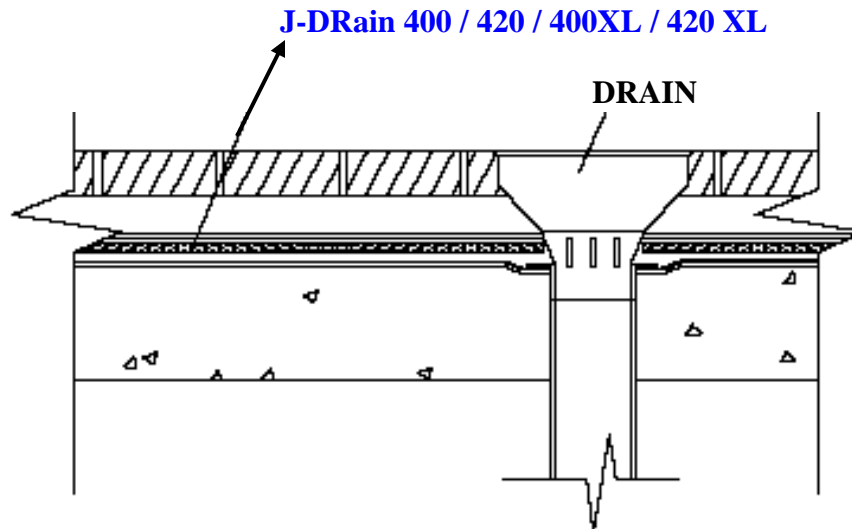

3904 Virginia Ave • Cincinnati, OH 45227 • Phone (513) 271-6000 • Fax (513) 271-4420

www.usfabricsinc.com